



FIELD OF APPLICATION AND INTENDED USE

The *Rapid Rig* is intended to be used with an appropriate rope to create a positive connection between the end of the rope and a TOGGLE floating on that rope, which can be used to make a choked termination around a solid object. It was designed for use in rigging, hauling, and winching. The purpose of this product is to provide a fast, consistent positive connection as an alternative to knots. The *Rapid Rig* should **never** be used for personal protective applications or for anchoring work positioning or life support lines.

WARNING

Rigging, hauling, or winching material of any weight is inherently dangerous and carries a significant risk of injury or death. The user is responsible for their own actions and decisions.

Before using this equipment:

- Read and understand all instructions for use.
- Understand, accept, and assume all risks and responsibilities for all damage, injury, or death that may result from use of this equipment.
- Fully understand and accept its capabilities and limitations.

Working with loads at height is a very dangerous activity which may lead to severe injury or fatality. It is the responsibility of the user to learn the safe and effective use of the *Rapid Rig*. If in doubt about the use of the product, users should seek training from a professional instructor on the use of the *Rapid Rig* in order to understand how it works and how to install and use it.

LIMITATION ON USE

It is impossible to identify all the ways this equipment can be misused. It must be used only for the specific purpose it was designed for and it must not be used for any other purpose. Refer to **Figures 1 - 10**. Only use configurations shown in the illustrations. Do not use for life support applications

ROPE SELECTION

The *Rapid Rig* should only be used with ropes from 3/16" (5mm) to 1/2" (12.7mm). Select a rope of the appropriate breaking strength, type, and size for the type and size of load as well as the environment of the operations. Only use 1/2" diameter arborist-grade rope for dynamic rigging operations in which the load will be subjected to falls and/or shock loads.

TOGGLE INSTALLATION

Thread the line through the TOGGLE LOOP and allow it to float freely. The TOGGLE should never be fixed to any point on the line.

NOTE: The TOGGLE and RING must be installed on the same line.

RING INSTALLATION

Install the RING on the end of the rope in only one of three ways:

- Use an appropriate tight eye splice to connect the end of the rope to the RING. The splice should be tight enough that the RING cannot rotate freely (**Figure 1**).
- Girth hitch a large spliced eye to the RING. Because two strands pass through the RING, a girth hitch with a larger diameter rope (1/2") may make using the *Rapid Rig* difficult (**Figure 2**).
- Tie the end of the rope to the RING using a cinching scaffold knot as illustrated in (**Figure 3**). Leave at least 3" of tail, with at least 2" covered by tape or heat shrink.

USE

The RING and TOGGLE connect to form a choking loop around a load. To connect the *Rapid Rig*, pass the RING and connected rope around the load, holding the TOGGLE so it stays on the front side of the load. Turn the TOGGLE so the TOGGLE BAR is perpendicular to the RING and pass it through the RING (**Figure 4**). Turn the TOGGLE so the TOGGLE BAR is parallel to the RING (**Figure 5**). Pull on the running end of the line to seat the TOGGLE (**Figure 6**). The TOGGLE BAR should lay across the RING, and the TOGGLE LOOP should sit inside the RING. When seated, the rope should not go through the RING. Once the *Rapid Rig* is seated properly, pull on the running end of the line to tighten the rope down onto the load. The user must be able to securely choke the device onto the load by hand in order to confirm the connection.

The *Rapid Rig* can be used with the TOGGLE BAR facing either toward or away from the load (**Figure 7**).

INCORRECT USE

Do not use the *Rapid Rig* with other connectors such as shackles or carabiners (**Figure 11 & 12**).

Do not load the rope without the TOGGLE completed seated in the RING (**Figure 13**).

Do not connect more than one leg of rope to the RING (**Figure 14**).

STRENGTH OF THE SYSTEM

Because of the variety of ropes compatible with the *Rapid Rig*, it is impossible to provide a strength rating for every combination of rope and the *Rapid Rig*. All bends and friction derate the breaking strength of a rope. However, testing with a variety of rope types and sizes shows that a system that uses the *Rapid Rig* is stronger than one that uses standard knots such as a bowline or a figure 8 follow through.

Tested with Ultra High Molecular Weight PolyEthylene ropes up to 1/2"; the rope always breaks before the *Rapid Rig*.

INSPECTION BEFORE AND AFTER EACH USE

Check all parts of parts of the *Rapid Rig* for cracks, deformation, corrosion, wear, etc. Small amounts of surface rust can be polished off before use.

Check the rope used with the *Rapid Rig* according to the manufacturer's instructions. Ensure the splice or knot used to connect the rope to the RING is tight and secure.

ON CHOKING CONFIGURATIONS

It is important to understand the limitations of a choking configuration that are present regardless of the termination, including the *Rapid Rig*, a knot, a steel choker, etc. In dynamic loading scenarios, where the load experiences falls and/or shock loads, specific circumstances can lead to an increased risk of the choking configuration slipping.

- On loads with smooth surfaces (like some tree trunks), it is possible for a choked termination to slip.
- If excessive slack is introduced into the system, the choked loop can loosen. If the loop is not secured properly, it is possible for the load to slip.

The user must use their judgement to decide in what situations to use and not to use the *Rapid Rig*.

There are some techniques that can be used to reduce the risks of using a choking configuration, including:

1. Installing the choking termination at 'stopper points' which prevent the rope from sliding along the load. In arboriculture, this can include appropriate branch unions of a tree limb or trunk (**Figure 8**) or cutting a small notch into the wood being rigged (**Figure 9**).
2. Tying a half hitch (or 'marl') around the load before connecting the *Rapid Rig* (**Figure 10**).

When choking around very small loads, the *Rapid Rig* may not tighten securely due to the increased diameter of the throat of a spliced connection limiting travel of the TOGGLE, depending on rope type and size. In this situation, wrap the RING end of the rope around the load one extra time before connecting the TOGGLE (**Figure 15**). This places the TOGGLE further down the line from the splice and allows for a secure connection.

WHEN TO RETIRE FROM SERVICE

Immediately retire the *Rapid Rig* if:

- Either part of the device is cracked or bent
- Either part has any sharp edges or burrs
- Any area of either part shows wear of more than 10% of the total part thickness
- There is persistent rusting
- There is any doubt regarding its integrity

INSPECTION DURING USE

It's important to regularly inspect the condition of all connections in the system, confirming all pieces of equipment are correctly positioned with respect to each other.

DETAILED INSPECTION

In addition to inspection before, during and after each use, a detailed inspection by a competent inspector must be done at least every 12 months or more frequently depending on amount and type of use. Make a copy of these instructions and use one as the permanent inspection record and keep the other with the equipment.

STORAGE

Always store the *Rapid Rig* in a dry place. If storing the device while installed on the rope, also follow the rope manufacturer's directions for storage.

LIFESPAN

The *Rapid Rig* has a ten year maximum service life and should be retired after ten years of use, even if it continues to pass inspection.

REPAIRS OR MODIFICATIONS

Do not repair or modify the product in any way unless specifically authorized in writing by the manufacturer.

If there is wear on the RING from contact with the TOGGLE equal to less than 10% of the thickness of the part, rotate the RING through the splice or knot by a quarter turn. This will increase the working life of the product.

OBSOLESCENCE

A product may become obsolete before the end of its lifespan. Reasons may include changes in applicable standards, regulations, legislation, development of new techniques, incompatibility with the other equipment, etc.

MARKINGS AND TRACEABILITY

Do not remove any markings or labels. Markings must remain legible during the entire lifespan of the product. The product can be traced through its own markings and the present user instructions manual.

GUARANTEE

Notch Equipment provides a lifetime guarantee against any defects in materials or manufacture. The guarantee does not cover this product from normal wear and tear, oxidation, modification, incorrect use or storage, poor maintenance, accidental damage, negligence or any usage for which the product was not designed.

Figure 1

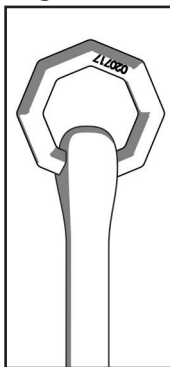

Figure 2

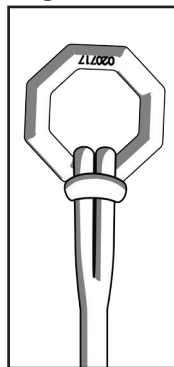

Figure 3

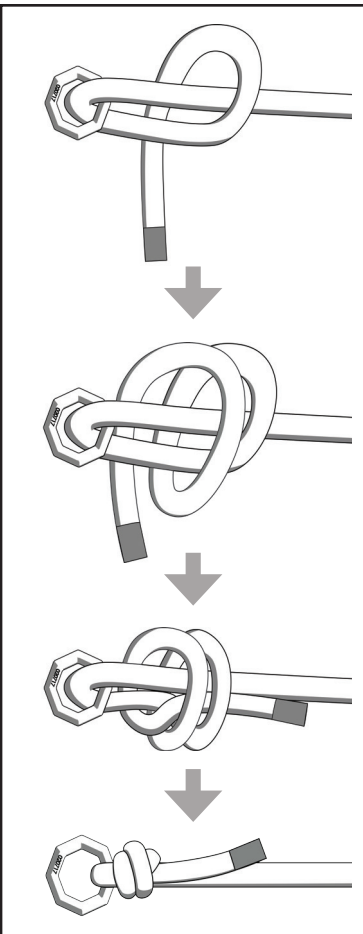

Figure 4

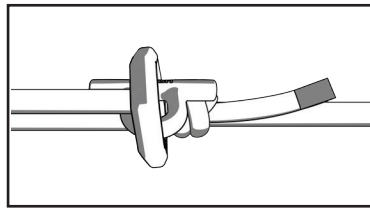

Figure 5

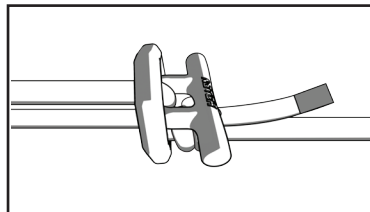

Figure 6

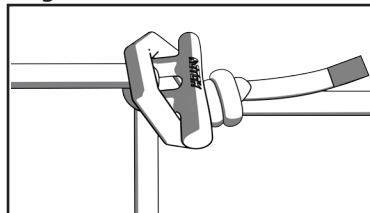

Figure 7

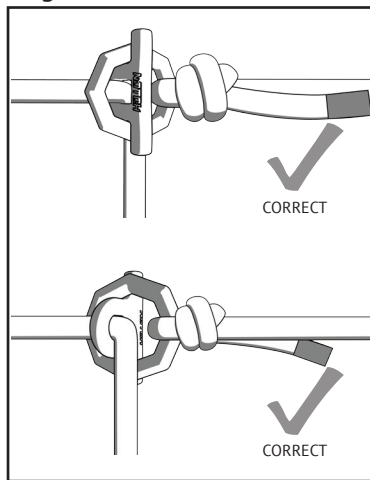

Figure 8

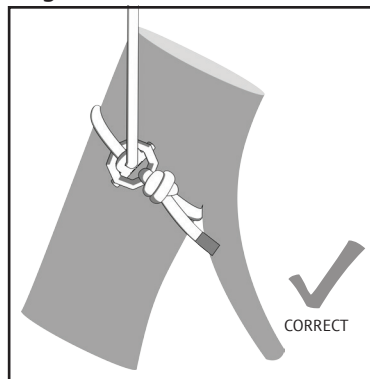

Figure 9

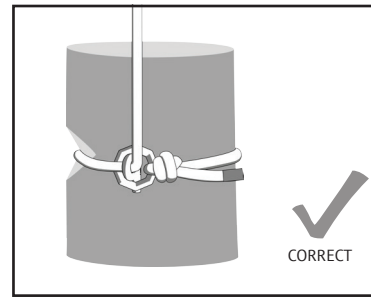

Figure 10

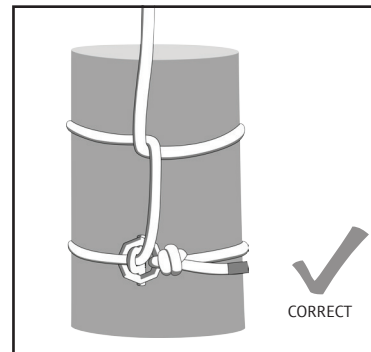

Figure 11

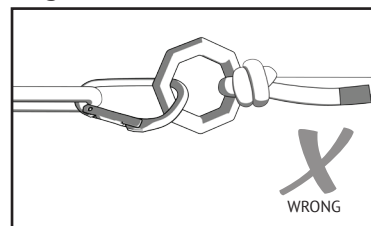

Figure 12

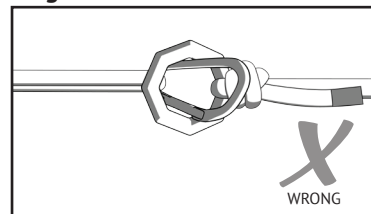

Figure 13

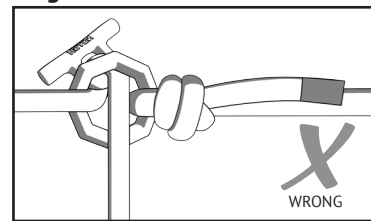

Figure 14

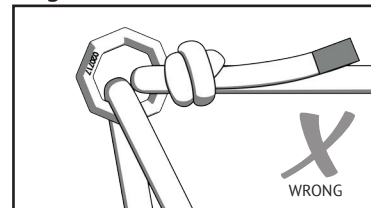
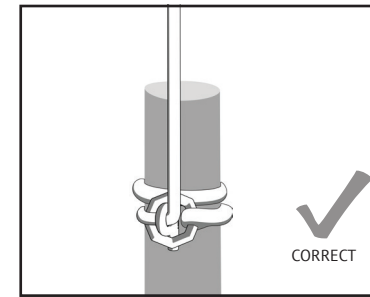
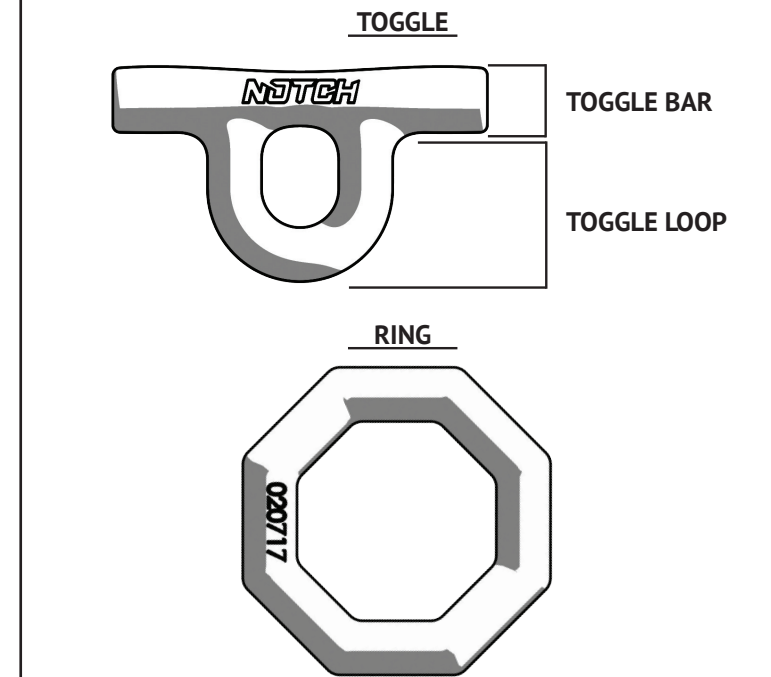

Figure 5



Nomenclature



MBS:	65 kN
Rope Diameter:	3/16" (5mm) to 1/2" (12.7mm)

PRODUCT DETAILS

Model	Notch Rapid Rig	
Batch Number		
Year of Manufacture		
Purchase Date		
Date of First Use		

INSPECTION RECORD

Date	Inspection Details & Condition	Inspector (Name & Signature)